



MDF820



MDF820I

Manual Dough Divider

Doyon is your best choice for a superior quality divider that frees you from the task of dividing your dough by hand while making it faster, easier and simpler. Better yet you'll be assured of uniformity in dough weight everytime.

Doyon's manual divider is ideal for rolls, tortillas, pizzas, breads, and much more...

MDF Series Dividers

*"Superior quality product
at an affordable price !"*

MDF Series Dividers

FEATURING

- Countertop model
- Models 15, 20 or 30 pieces
- Sanitary dough press head
- Stainless steel dough pan included
- Uniformly scales pieces
- No oil in or above product zone
- Cutting knives are stainless steel for sanitary purpose
- Head can be tilted for easy cleaning
- Virtually maintenance free: extremely durable
- Weight range depending on dough consistency
- One year parts and labor limited warranty

OPTIONAL

- SS2830 stainless steel table on casters
- Stainless steel construction (MDF315I, MDF330I, MDF820I & MDF830I)

NUMBER OF PORTIONS

MDF315 : 15
MDF330 : 30
MDF820 : 20
MDF830 : 30

PORTION WEIGHT RANGE

MDF315 : 1.75 oz to 7 oz (50g to 200g)
MDF330 : 0.71 oz to 3.5 oz (20g to 100g)
MDF820 : 1.75 oz to 14 oz (50g to 400g)
MDF830 : 1.1 oz to 9.3 oz (31g to 265g)

TOTAL DOUGH WEIGHT

MDF315 : 1.6 lb to 6.5 lb (0.75 kg to 3 kg)
MDF330 : 1.3 lb to 6.6 lb (0.6 kg to 3 kg)
MDF820 : 2 lb to 17 lb (0.75 kg to 7.5 kg)
MDF830 : 2 lb to 17.5 lb (0.9 kg to 7.95 kg)

CRATED WEIGHT

400 lb (182 kg) approximately

MDF315 - MDF330

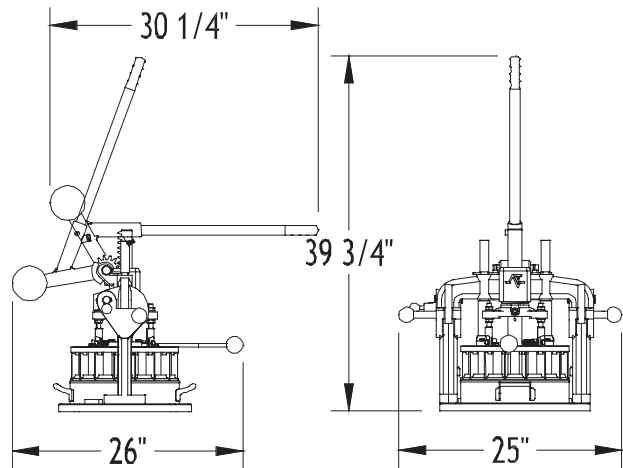

MDF820 - MDF830

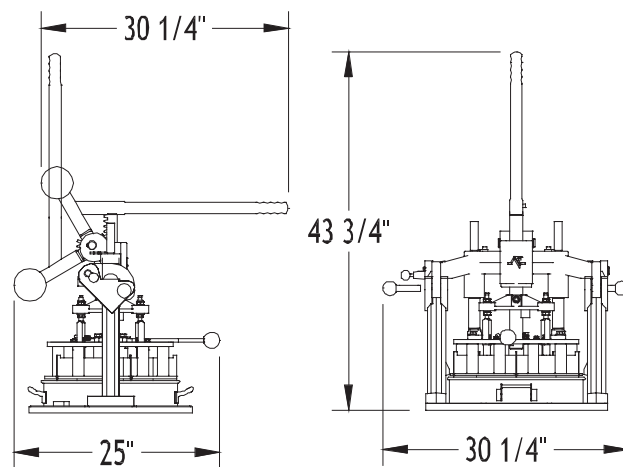

MDF830



1255, rue Principale
Linière, Beauce, Québec, Canada G0M 1J0

Telephone : (418) 685-3431 Fax: (418) 685-3948
Canada : (800) 463-1636 U.S.: (800) 463-4273
E-Mail : doyon@doyon.qc.ca Internet: http://www.doyon.qc.ca

Your local distributor:

