



SPECIFICATIONS:

35 - 40 lb. capacity free standing model gas fryer, Vulcan-Hart Model No. LG300. Stainless steel front top and door. Set of 4 adjustable nickel plated steel legs. Stainless steel fry tank with three heat exchanger tubes and a "V" shaped cold zone. 1 1/4" full port ball type drain valve. Twin fry baskets with plastic coated handles. 90,000 BTU/hr. input. Behind the door millivolt thermostat control adjusts from 200° to 400°F.

Overall dimensions: 15 1/2"w x 30 1/4"d x 36 1/4"h.

CSA design certified. NSF listed.

SPECIFY TYPE OF GAS WHEN ORDERING.

- Natural Gas
- Propane Gas

SPECIFY ALTITUDE:

- Natural Gas for above 2000 ft
- Propane Gas for above 3500 ft.

STANDARD FEATURES

- Stainless steel fry tank, 35 - 40 lb. capacity.
- 1 1/4" full port ball type drain valve.
- Stainless steel front top and door.
- Set of 4 adjustable nickel plated legs.
- Twin fry baskets with plastic coated handles.
- 90,000 BTU/hr. input.
- Behind the door millivolt thermostat control adjusts from 200° to 400°F.
- Three heat exchanger tubes positioned for easy cleaning.
- Hi-limit shut-off.
- Combination gas shut-off valve and manual pilot ignition system.
- Vulcan-Hart (Vulcan) warrants the LG300 Gas Fryer to be free of defects in materials and workmanship for a period of 90 days from the date of original installation.
- Stainless steel fry tank will be warranted for 1 year. If tank is found to be leaking and verified by an authorized service agency, the entire LG300 fryer will be replaced. Replacement fryer will be warranted for 90 days or for the balance of the original warranty whichever comes first.

ACCESSORIES

- Casters 6" adjustable - 2 locking, 2 non-locking
- Stainless steel tank cover.
- Grease protector strips.
- Single large basket - 13"w x 13 1/4"d x 5 1/2"h.
- Set of twin baskets - 6 1/2"w x 13 1/4"d x 6"h.
- Set of tri baskets - 4 1/4"w x 13 1/4"d x 5 1/2"h
- FRYMATE - VX15 add-on frymate.
- Flexible gas hose with quick disconnect.



LG300

FREE STANDING GAS FRYER

IMPORTANT

1. A combination valve with pressure regulator is provided with this unit.
Natural Gas 4.0" (102 mm) W.C.
Propane Gas 10.0" (279 mm) W.C.
2. An adequate ventilation system is required for Commercial Cooking Equipment. Information may be obtained by writing to the National Fire Protection Association, Batterymarch Park, Quincy, MA 02269. When writing refer to NFPA No. 96.
3. All models require a 6" (152 mm) clearance at both sides and rear adjacent to combustible construction.
4. All models require a 16" (407 mm) minimum clearance to adjacent open top burner units.
5. This appliance is manufactured for commercial installation only and is not intended for home use.

SERVICE CONNECTIONS:

- (P1) 1/2" (13 mm) rear gas connection (single units).

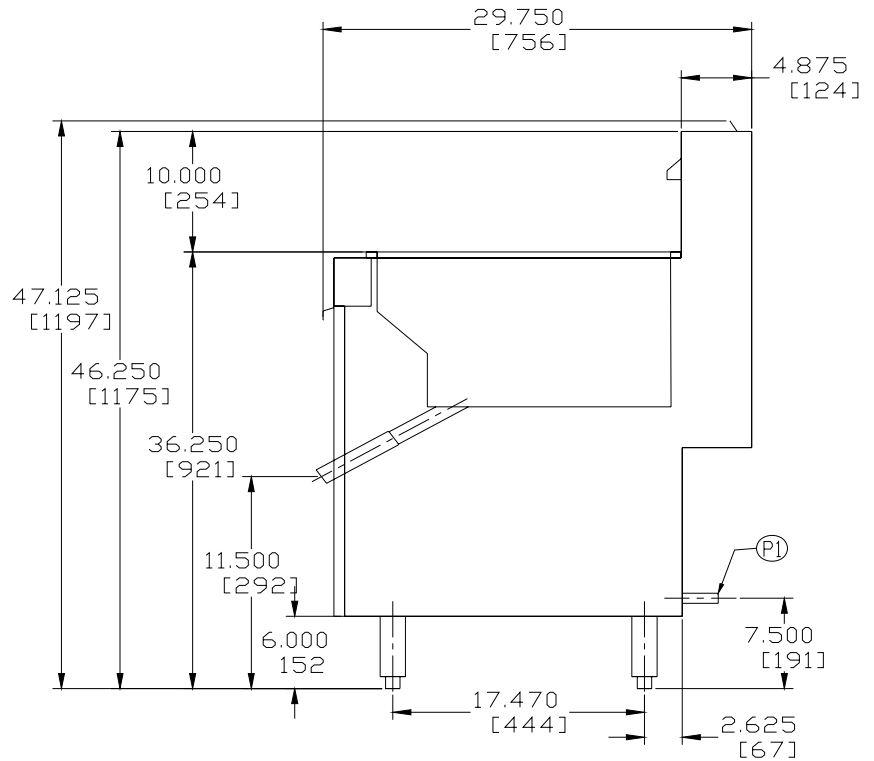
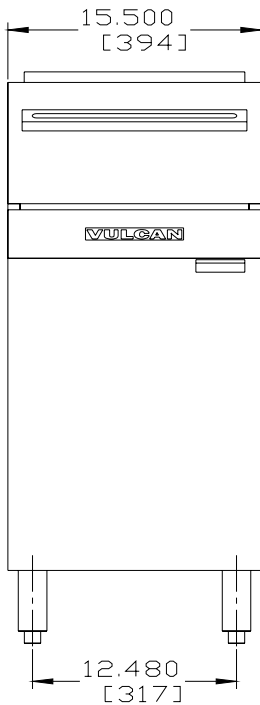
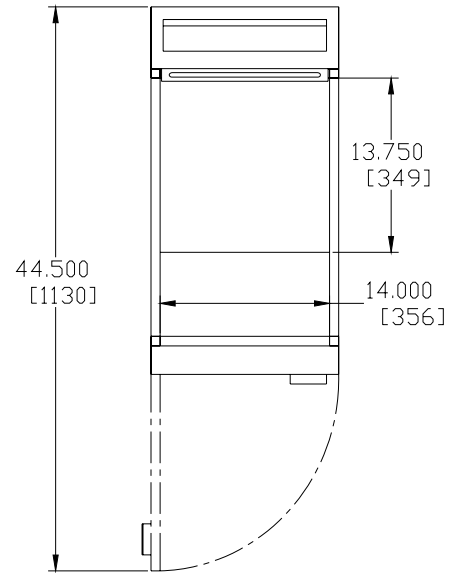

MODEL	WIDTH	DEPTH	OVERALL HEIGHT	WORKING HEIGHT	TANK SIZE	BTU/HR.	FRY COMP. CAPACITY	APPROX. SHP.WT.
LG300	15 1/2"	30 1/4"	47 1/8"	36 1/4"	14" x 14"	90,000	35 - 40 lbs.	200 lbs./91 kg

NOTE: In line with its policy to continually improve its products, Vulcan-Hart Company reserves the right to change materials and specifications without notice.