

**HOBART**701 S Ridge Avenue, Troy, OH 45374  
1-888-4HOBART • www.hobartcorp.com**WORLD SCALE****HOBART****STANDARD FEATURES**

- Stylish and compact
  - The WP/WC is attractively designed and is tough enough to withstand everyday professional use. It offers the perfect combination of compact footprint and a spacious platter manufactured in high quality stainless steel.
- Remarkably affordable
- Simple touch key operation
- Wipe clean keypad with audible “beep”
- Fully automatic zero correction
- Stainless steel weighing platter
- Very fast response to weight changes
- Resolutions up to 30 lb. x .005
  - Whatever you want to weigh, from delicate items to product in bulk, the WP/WC delivers the capacity and resolution you need.
- Powered by six D-cell batteries or AC adaptor
  - The WP/WC gives you the power to use your scale in most weighing situations, by offering a choice of electric or battery power. Take advantage of the battery option and the unit is instantly portable, offering up to 800\* hours of continuous operation without the need to recharge or replace the batteries  
(\*Subject to the quality of batteries used.)
- Large LCD display
- Optional rechargeable module charges in or out of scale
- Up to 20 PLU memory locations store pricing for your most popular items
- Digital load cell – finer resolution than competing units
- Add key – add pricing of weighed and non-weighed items for up to 99 transactions

**MODELS**

- WP30-1
- WC30-1

**OPTIONS AT EXTRA COST**

- AC Adaptor
- Candy scoop

Specifications, Details and Dimensions on Reverse Side.



WC30-1



WP30-1

**WORLD SCALE**

## SPECIFICATIONS

**CAPACITY:** 12 lbs. x 0.002 lbs.; 30 lbs. x 0.005 lbs.;  
60 lbs. x 0.01 lbs.

**PLATTER:** Stainless steel, 11.8" x 8.7".

**DISPLAY:** LCD custom panel with 0.5" high digits  
(12 mm).

**KEYBOARD:** Membrane keyboard with audio  
feedback.

**ELECTRICAL:** AC Adaptor: Input – 120 VAC,  
Output – 12 VDC.

**WEIGHT:** Net: 8.1 lb. (3.67 kg); Shipping: 10.6 lb.  
(4.8 kg).

## DETAILS AND DIMENSIONS

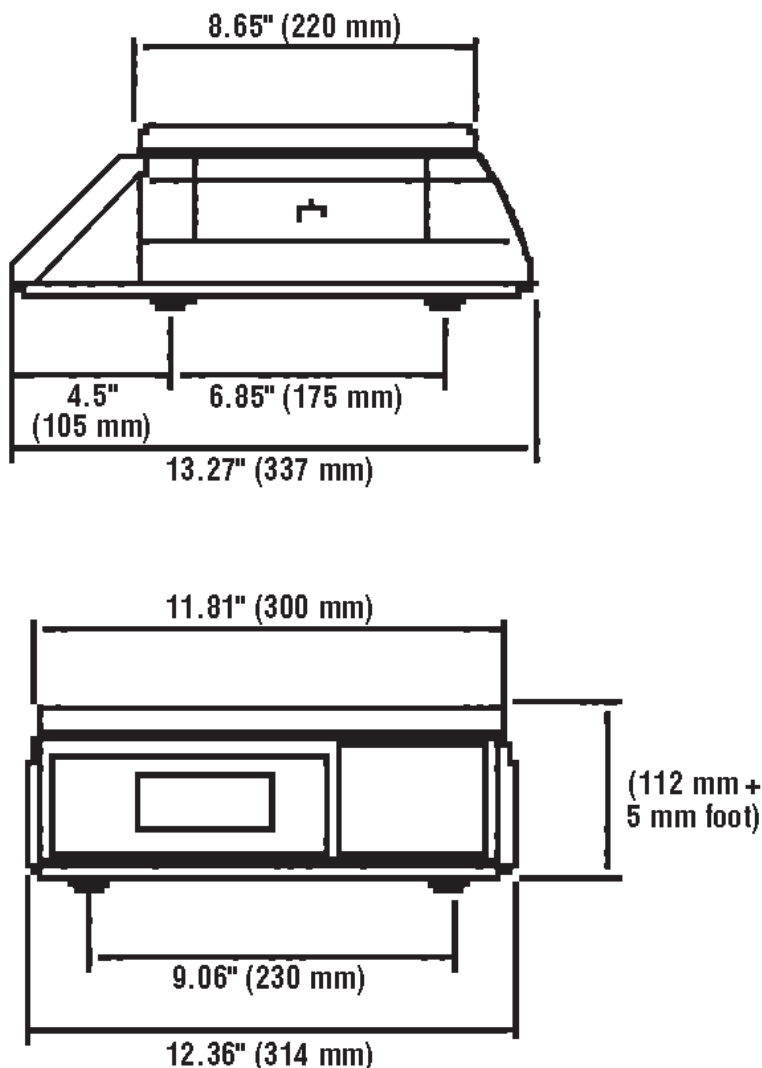

As continued product improvement is a policy of Hobart, specifications are subject to change without notice.